

htc®



Arcade Best Practice

Contents

ROOM SPACE DESIGN	3
INSTALLING BASE STATION	4
3-in-1 CABLE HANGING STICK	5
HYGIENE	6

ROOM SPACE DESIGN

To have a play area (room-scale experience) of 3x3 meter, a minimum room space **4.5x4.5** meter is recommended:

- To get a better experience in an Arcade, a 3x3 meter play area is highly recommended. This size fulfills the requirement of most games (ex: room-escape).
- Most customers come to Arcade stores with friends and/or family. A place for multiple people to experience VIVE is recommended. A 4.5x4.5 meter play area could contain a PC, TV screen, chairs, and sofa.
- It is better to use speakers rather than headphones. This allows customers and their friends/family to hear and enjoy the experience together.

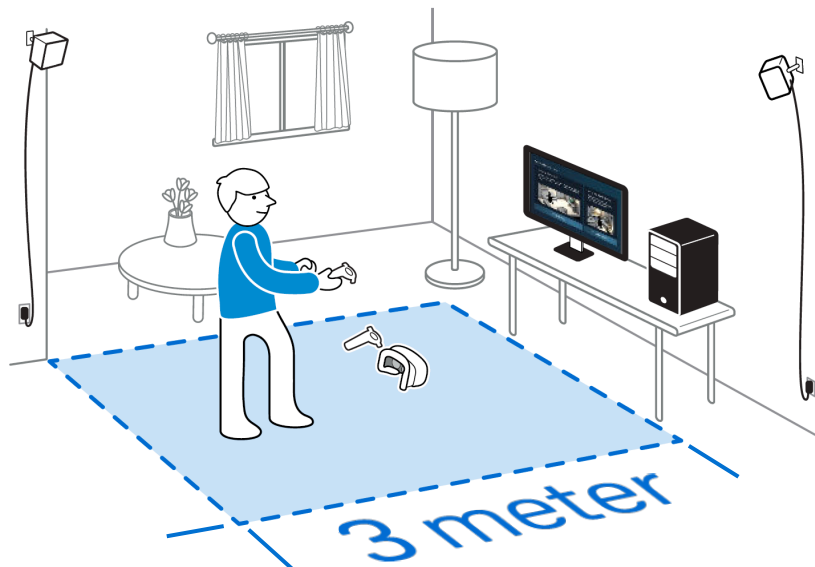

INSTALLING BASE STATION

Correctly mounting the base stations leads to better position tracking. The following is guidelines to install base stations:

- Position the base stations diagonally across the room and above your height.
- Make sure the maximum distance between two base stations is 5 meters.
- Every HMD can only see (at most) two base stations. The third base station might interfere with position tracking and cause loss of tracking. The tracking distance is around 5 meters, but laser signal might transit 8-10 meters.

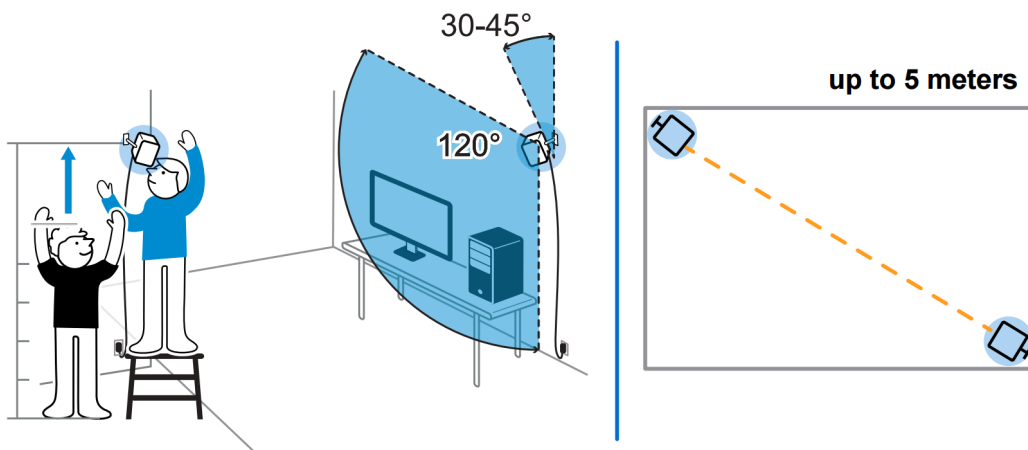

- Avoid using any **mirror** material in decoration. Mirror would reflect laser signals and interfere with HMD tracking.
- In an arcade environment, we suggest use of light-shielding material as the partition between each play area. For example, a thick and light-blocking black cloth or a wooden/plywood board are good solutions.

3-in-1 CABLE HANGING STICK

To get a better experience and improve safety, it is highly recommended to hang the 3-in-1 cable with a stick. The best hanging position is behind the player. This helps taller customers avoid striking the stick especially while throwing something in virtual reality.



Figure 1 Normal 3-1 Cable setup

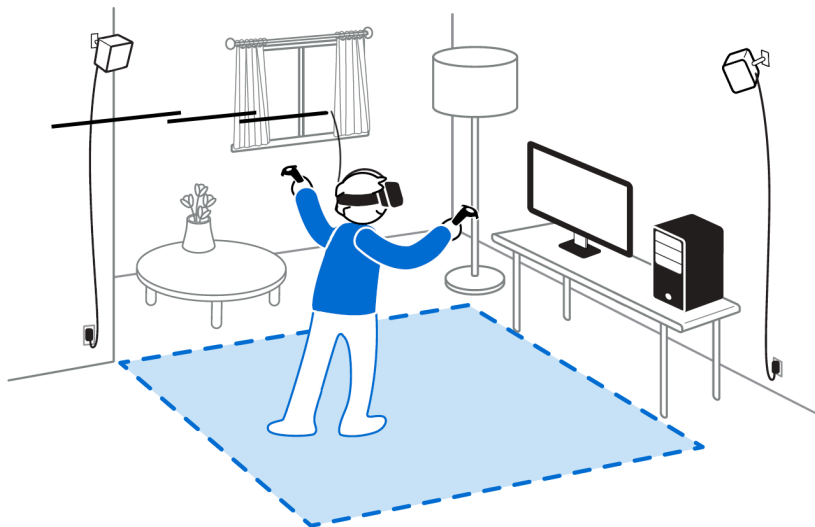

Figure 2 Recommend hanging 3-1 Cable with stick

HYGIENE

Hygiene is very important for Arcade store, since equipment will be used by many different customers. It is recommended to prepare the following materials:

- **HTC VIVE Cover: PU Leather**

Material PU Leather could avoid sweat absorption, and is easier to clean. Recommend to replace PU Leather with the original foam.



- **Disposable White Mask**

Disposable white mask could avoid directly skin contact with HMD. Staff should deliver disposable white mask to every customer before experience VR.



- **Alcohol Cotton Wipes**

Staff should clean HMD and Controllers between every customer session.

